

The gravimetric feeders of the DG series have been designed to automatically and accurately dose master and additives.

The synergy between design, applied technology and material quality results in high flexibility. These feeders can be installed on injection moulding machines, blow-moulding machines and extruders.

Two versions available:

- base version with manual loading of material.
- advanced version with automatic loading of material by means of a Venturi feeder.



#### TECHNICAL SPECIFICATIONS:

- Inclined-axis feeder.
- Brushless motor.
- Remote 4" color touchscreen operator panel.
- Load cells.
- Lower slide gate to discharge material.
- Central flanged base to install up to 2 units.
- Complete with static mixer.
- ModBus interface.
- ETHERNET connector.
- USB connection.
- Connection to PC.

#### ACCESSORIES:

- Removable touchscreen display.
- Mixer.
- Venturi feeder.

#### ADDED VALUE:

- USB port to download recipes and weigh logs into an external storage device.
- Fast colour change and cleaning thanks to a complete accessibility to the unit.
- A wide range of dosing screws and cylinders that can be easily and quickly interchanged.
- Calibration without waste of material.
- Auto-tuning of the material to be dosed.
- Lack of material detected by load cells and signalled by a specific warning device.

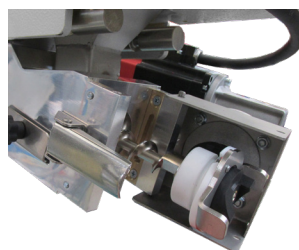
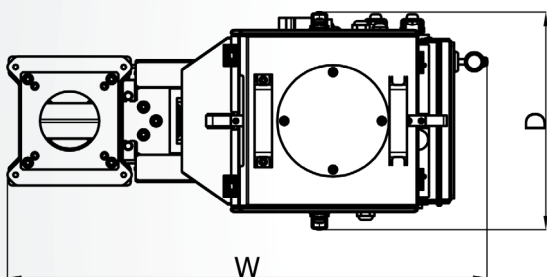
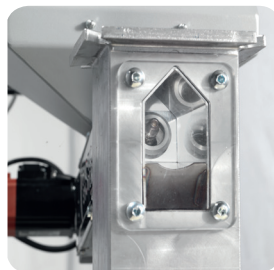
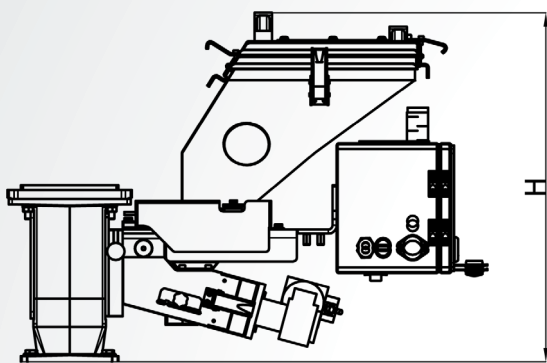

TECHNICAL DATA	Screws D x P	Gear ratio	DG10
Minimum-maximum throughput [kg/h]	8x8	1:38	0.09-1.17**
		1:75	0.03-0.40**
	12x8	1:38	0.24-3.57*
	16x10	1:38	0.63-9.41*
	20x20	1:38	1.33-17.64*
Maximum no. of materials			2
Hopper volume		dm <sup>3</sup>	10
Feeder motor power		kW	0.20
Motor speed		r.p.m.	3000
Mixer motor power (opt.)		kW	0.2
Mixing chamber capacity (opt.)		dm <sup>3</sup>	3
Voltage/Frequency		V/Hz	230/50-60
Noise level		dB(A)	<80
Dimensions WxDxH		mm	687 <sup>1</sup> x313x500
Weight		kg	18

1) Consider additional 150mm necessary for the calibration procedure.

Throughput values specified in the table have been obtained with:

[\*] masterbatch granules measuring 2.5x3 mm, psa (bulk density) 0,784 kg/dm<sup>3</sup>

[\*\*] masterbatch microgranules measuring 1.12x1.01mm, psa (bulk density) 0,601 kg/dm<sup>3</sup>